

Department of Transportation
Office of Legal Counsel
700 East Broadway Avenue
Pierre, South Dakota 57501-2586 605/773-3262
FAX: 605/773-4442

MEMORANDUM

TO: Patricia Saukel
FROM: Karla L. Engle
DATE: August 15, 2017
RE: August 24, 2017, Commission Meeting

The Department of Transportation asks the Transportation Commission to approve amendments to the following administrative rules:

- 70:01:02:01 – Minnehaha County speed zone rule
- 70:01:02:06 – Brookings County speed zone rule
- 70:01:02:44 – Lincoln County speed zone rule
- 70:01:02:67 – Todd County speed zone rule

Copies of the following documents are enclosed with this memo:

1. The proposed rules;
2. Four memos from traffic engineering staff, outlining the purpose and effect of each of the proposed rule changes;
3. The Rules Presentation Format Form, listing the procedural steps that have been taken so far in the rule adoption process.

Thank you.

KLE
Enclosures

CHAPTER 70:01:02**SPEED LIMITS**

70:01:02:01. Minnehaha County. The following are the maximum speeds on certain highways in Minnehaha County:

(1) State Trunk Highway 42 beginning 2.17 miles east of the intersection with State Trunk Highway 11 going south, then east for 2.79 miles, 55 miles per hour; then east for 0.15 mile, 45 miles per hour; then east for 0.37 mile through Rowena, 30 miles per hour; then east for 0.18 mile, 45 miles per hour; then east for 2.54 miles to the South Dakota/Iowa border, 55 miles per hour;

(2) State Trunk Highway 38 beginning 0.2 mile west of Western Avenue then east to Western Avenue, 45 miles per hour; then southeasterly through Hartford for 1.1 miles, 35 miles per hour; then southeasterly for 0.53 mile, 50 miles per hour;

(3) State Trunk Highway 38 beginning at a point 0.2 mile west of the west junction with State Trunk Highway 19, then east for 0.9 mile to west of Washington Street in Humboldt, 55 miles per hour; then east for 0.4 mile, 35 miles per hour; then east for 0.2 mile, 55 miles per hour;

(4) Repealed;

(5) Repealed;

(6) State Trunk Highway 11 beginning at the intersection with Aspen Boulevard at Brandon, then north for 0.63 mile through Brandon to Needles Drive, 30 miles per hour; then north 0.78 mile to the centerline of Interstate Highway 90, 45 miles per hour;

(7) Repealed;

(8) Repealed;

(9) State Trunk Highway 11 beginning at the centerline of Interstate Highway 90, then north 0.32 mile, 45 miles per hour; then north through Corson for 0.55 mile, 35 miles per hour; then north 0.1 mile, 45 miles per hour;

(10) State Trunk Highway 115 beginning ~~0.4~~ 1.56 mile southeasterly of the intersection with Fourth Street in Dell Rapids, then northwesterly for ~~0.2 mile~~ 1.08 miles, ~~45~~ 55 miles per hour; then northwesterly for ~~0.2~~ 0.48 mile to Fourth Street, ~~30~~ 35 miles per hour; then west for ~~0.2~~ 0.66 mile, ~~30~~ 35 miles per hour; then west for ~~0.45~~ 0.2 mile, ~~45~~ 50 miles per hour;

(11) State Trunk Highway 115 beginning at the Lincoln County Line, 57th Street in Sioux Falls, then north to Interstate 229, 40 miles per hour; then north to Russell Street, 30 miles per hour; then northeasterly via North Drive to Cliff Avenue, 35 miles per hour; then north to a point 0.35 mile north of the junction of Interstate 90, 40 miles per hour; then north to a point 0.6 mile north of Minnehaha County road 130 (Renner Corner), 55 miles per hour;

(12) State Trunk Highway 42 beginning at its junction with Minnehaha County Highway 139 (Ellis Road), then east to the Skunk Creek Bridge, 45 miles per hour; then east to Kiwanis Avenue in Sioux Falls, 35 miles per hour; then east to the end of State Trunk Highway 42 at its junction with State Trunk Highway 38 at West Avenue, 30 miles per hour;

(13) State Trunk Highway 42 beginning at the intersection with West Avenue in Sioux Falls, then east to Spring Avenue, 30 miles per hour; then east to Second Avenue, 20 miles per hour; then east to Cleveland Avenue, 30 miles per hour; then east to a point 0.5 mile east of the intersection with Sycamore Avenue, 35 miles per hour; then east to the junction with State Trunk Highway 11 South, 45 miles per hour; then east 2.17 miles, 55 miles per hour;

(14) State Trunk Highway 11 beginning at the intersection with Aspen Boulevard at Brandon, then southwesterly for 0.3 mile, 30 miles per hour; then southwesterly 0.9 mile, 45 miles per hour; then south to the junction of State Trunk Highway 42, 55 miles per hour;

(15) Repealed;

(16) The crossroad over Interstate Highway 90 at Exit 402 beginning at a point 0.2 mile north of the centerline of Interstate Highway 90, then south 0.4 mile, 40 miles per hour;

(17) The crossroad over Interstate Highway 90 at Exit 410 beginning at a point 0.2 mile north of the centerline of Interstate Highway 90, then south 0.4 mile, 25 miles per hour;

(18) State Trunk Highway 11 beginning 0.78 mile south of Dows Street in Garretson, then north 0.58 mile, 55 miles per hour; then north 0.56 mile, 45 miles per hour; then north 0.46 mile, 55 miles per hour;

(19) State Trunk Highway 11 beginning at the Minnehaha - Lincoln County line, then north for 1.66 miles, 55 miles per hour, then north for 1.4 miles to Arrowhead Parkway in Sioux Falls, 45 miles per hour;

(20) State Trunk Highway 42 beginning 0.9 mile west of the intersection with Minnehaha County Highway 139, then east for 0.8 mile, 55 miles per hour, then east for 0.1 mile, 45 miles per hour.

Source: SL 1975, ch 16, § 1; 2 SDR 86, effective June 24, 1976; 4 SDR 20, effective October 3, 1977; 4 SDR 26, effective October 31, 1977; 4 SDR 77, effective March 2, 1978; 5 SDR 31, effective October 30, 1978; 6 SDR 63, effective December 30, 1979; 6 SDR 109, effective May 29, 1980; 7 SDR 1, effective July 20, 1980; 8 SDR 45, effective October 28, 1981; 9 SDR 7, effective July 27, 1982; 11 SDR 112, effective February 25, 1985; 13 SDR 52, effective November 6, 1986; 13 SDR 129, 13 SDR 134, effective July 1, 1987; 14 SDR 14,

effective August 2, 1987; 14 SDR 65, effective November 5, 1987; 15 SDR 158, effective April 26, 1989; 16 SDR 40, effective September 7, 1989; 17 SDR 127, effective March 3, 1991; 19 SDR 154, effective April 11, 1993; 20 SDR 183, effective May 9, 1994; 22 SDR 165, effective June 2, 1996; 22 SDR 183, effective June 30, 1996; 23 SDR 132, effective February 27, 1997; 24 SDR 15, effective August 10, 1997; 26 SDR 85, effective December 29, 1999; 26 SDR 110, effective March 6, 2000; 28 SDR 181, effective July 4, 2002; 29 SDR 43, effective October 8, 2002; 29 SDR 160, effective June 2, 2003; 34 SDR 303, effective June 9, 2008; 36 SDR 27, effective August 20, 2009; 37 SDR 182, effective April 20, 2011; 38 SDR 8, effective August 3, 2011; 38 SDR 172, effective April 24, 2012; 41 SDR 34, effective September 2, 2014; 41 SDR 173, effective May 11, 2015.

General Authority: SDCL 32-25-7.

Law Implemented: SDCL 32-25-7.

70:01:02:06. Brookings County. The following are the maximum speeds on certain highways in Brookings County:

(1) U.S. Highway 14 beginning 0.3 mile west of Brookings County Road 5 at Volga, then east for 0.20 mile, 45 miles per hour; then east for 0.76 mile, 35 miles per hour; then east for 0.75 mile, 50 miles per hour;

(2) Repealed;

(3) Repealed;

(4) U.S. Highway 14 beginning 0.21 mile west of Brookings County Road 9, then east and south for 1.41 miles, 55 miles per hour; then southeasterly for 0.25 mile, 40 miles per hour; then

east for 1.68 miles, 30 miles per hour; then east for ~~0.98 mile~~ 1.40 miles, 35 miles per hour; ~~then east for 0.36 mile, 45 miles per hour;~~ then east for ~~0.16~~ 0.20 mile, ~~55~~ 50 miles per hour;

(5) State Trunk Highway 324 over Interstate Highway 29 at Exit 127 beginning at a point 0.2 mile west of the centerline of Interstate Highway 29, then east 0.5 mile, 40 miles per hour;

(6) U.S. Highway 14 at the junction of Brookings County Road 9, then east 0.18 mile to U.S. Highway 14 Bypass, then east 3.83 miles, 55 miles per hour;

(7) State Trunk Highway 30 beginning 0.15 mile west of its junction with Brookings County Road 25, then east for 0.30 mile, 45 miles per hour.

Source: SL 1975, ch 16, § 1; 6 SDR 109, effective May 29, 1980; 7 SDR 25, effective September 22, 1980; 10 SDR 52, effective November 30, 1983; 13 SDR 179, effective June 1, 1987; 13 SDR 129, 13 SDR 134, effective July 1, 1987; 17 SDR 127, effective March 3, 1991; 22 SDR 165, effective June 2, 1996; 25 SDR 118, effective April 1, 1999; 25 SDR 167, effective July 4, 1999; 26 SDR 124, effective April 2, 2000; 27 SDR 32, effective October 10, 2000; 29 SDR 147, effective May 8, 2003; 30 SDR 89, effective December 7, 2003; 34 SDR 180, effective December 24, 2007.

General Authority: SDCL 32-25-7.

Law Implemented: SDCL 32-25-7.

70:01:02:44. Lincoln County. The following are the maximum speeds on certain highways in Lincoln County:

(1) U.S. Highway 18 beginning 0.85 mile west of West Street in Canton, then east to West Street, 45 miles per hour; then east to Blair Street, 35 miles per hour; then east to Milwaukee Street, 25 miles per hour; then east to Lawler Street, 35 miles per hour; then east to a location

100 feet east of Noid Street, 45 miles per hour; then east 2.51 miles to the Iowa border, 55 miles per hour;

(2) State Trunk Highway 44 beginning 0.19 mile west of the intersection of Lincoln County Highway 117, then easterly through Worthing for 0.63 mile, 35 miles per hour;

(3) State Trunk Highway 46 beginning 0.45 mile west of the centerline of Interstate Highway 29, then east for 0.3 mile, 45 miles per hour; then east for 0.65 mile, 35 miles per hour; then east for 1 mile through Beresford to E. 13th St. (472 Ave.), 30 miles per hour; then east for 0.25 mile, 45 miles per hour;

(4) State Trunk Highway 17 beginning at the intersection with State Trunk Highway 44, then north for 1.4 miles past Lennox, 45 miles per hour;

(5) State Trunk Highway 115 beginning at a point 0.53 mile south of Lincoln County Road 110 (Harrisburg corner), then north 4.25 miles to a point 0.28 mile south of the intersection with 69th Street in Sioux Falls, 55 miles per hour; then north to the Lincoln County Line at 57th Street in Sioux Falls, 40 miles per hour;

(6) State Trunk Highway 44 beginning 0.25 mile west of the centerline of Interstate 29, then east 0.5 mile, 40 miles per hour;

(7) The crossroad over Interstate Highway 29 at Exit 50 beginning at a point 0.25 mile west of the centerline of Interstate Highway 29, then east 0.5 mile, 30 miles per hour;

(8) The crossroad over Interstate Highway 29 at Exit 53 beginning at a point 0.2 mile west of the centerline of Interstate Highway 29, then east 0.4 mile, 25 miles per hour;

(9) The crossroad over Interstate Highway 29 at Exit 56 beginning at a point 0.2 mile west of the centerline of Interstate Highway 29, then east 0.4 mile, 40 miles per hour;

(10) U.S. Highway 18 and the Lincoln County road over Interstate Highway 29 at Exit 59 beginning at a point 0.25 mile west of the centerline of Interstate Highway 29, then east 0.1 mile, 45 miles per hour; then east 0.4 mile, 35 miles per hour;

(11) U.S. Highway 18 ~~and the Lincoln County road~~ over Interstate Highway 29 at Exit 62 beginning at a point ~~0.25~~ 0.17 mile west of the centerline of Interstate Highway 29, then east ~~0.5~~ 0.53 mile, ~~40~~ 55 miles per hour;

(12) The crossroad over Interstate Highway 29 at Exist 68 beginning at a point 0.15 mile west of the centerline of Interstate Highway 29, then east 0.3 mile, 25 miles per hour;

(13) The crossroad over Interstate Highway 29 at Exit 71 beginning at a point 0.15 mile west of the centerline of Interstate Highway 29, then east 0.3 mile, 25 miles per hour;

(14) The crossroad over Interstate Highway 29 at Exit 73 beginning at a point 0.15 mile west of the centerline of Interstate Highway 29, then east 0.3 mile, 25 miles per hour;

(15) Repealed;

(16) State Trunk Highway 44 at Lennox beginning 1.05 miles west of the junction with State Trunk Highway 17 at Lennox, then east for 0.55 mile to a point 200 feet west of Elm Street, 45 miles per hour; then east for 0.5 mile, 30 miles per hour; then south for 0.28 mile, 45 miles per hour;

(17) State Trunk Highway 11 beginning 0.95 mile south of the Minnehaha - Lincoln County line, then north for 0.95 mile to the Minnehaha - Lincoln County line, 55 miles per hour.

Source: SL 1975, ch 16, § 1; 5 SDR 91, effective April 29, 1979; 6 SDR 109, effective May 29, 1980; 7 SDR 1, effective July 20, 1980; 8 SDR 154, effective May 26, 1982; 13 SDR 52, effective November 6, 1986; 13 SDR 129, 13 SDR 134, effective July 1, 1987; 15 SDR 185, effective June 4, 1989; 16 SDR 169, effective April 25, 1990; 17 SDR 127, effective March 3,

1991; 19 SDR 30, effective August 30, 1992; 20 SDR 183, May 9, 1994; 22 SDR 165, effective June 2, 1996; 26 SDR 44, effective October 4, 1999; 26 SDR 85, effective December 29, 1999; 28 SDR 24, effective August 29, 2001; 30 SDR 171, effective May 11, 2004; 33 SDR 43, effective September 19, 2006; 33 SDR 125, effective January 29, 2007; 37 SDR 182, April 20, 2011.

General Authority: SDCL 32-25-7.

Law Implemented: SDCL 32-25-7.

70:01:02:67. Todd County. The following are the maximum speeds on certain highways in Todd County:

(1) U.S. Highway 18 ~~and U.S. Highway 83~~ beginning 2.1 miles west of the junction of U.S. Highway 18 and U.S. Highway 83 in Mission, then east for 1.1 miles, 45 miles per hour; then east for ~~1.4 miles~~ 1.0 mile to the junction of U.S. Highway 18 and U.S. Highway 83 in Mission, 30 miles per hour; then east on U.S. Highway 18 for 0.98 mile, 30 miles per hour; then east for ~~1.4~~ 1.23 miles, 45 miles per hour;

(2) U.S. Highway 83 beginning at the junction of U.S. Highway 18 and U.S. Highway 83 in Mission, then south for 0.3 mile, 30 miles per hour; then south for 0.65 mile, 35 miles per hour; then south for 0.2 mile, 45 miles per hour;

(3) State Trunk Highway 63 beginning 0.15 mile west of the north-south quarter section line of section 30, township 39 north, range 31 west of the sixth principal meridian, then east for 0.45 mile, 30 miles per hour;

(4) State Trunk Highway 63 beginning at its junction with U.S. Highway 18, then north to a point 0.3 mile east of the north-south quarter-section line of section 30, township 39 north, range 31 west of the sixth principal meridian, 55 miles per hour;

(5) State Trunk Highway 63 beginning 0.15 mile west of the north-south quarter-section line of section 30, township 39 north, range 31 west of the sixth principal meridian, then west and north to the Todd-Mellette county line, 55 miles per hour;

(6) U.S. Highway 18 beginning 0.25 mile southwest of the northwest corner of section 15, township 39 north, range 26 west, then northeast 0.61 mile, 55 miles per hour;

(7) U.S. Highway 18 beginning 0.65 mile west of the Little White River bridge, then northeast 0.72 mile, 55 miles per hour.

Source: SL 1975, ch 16, § 1; 1 SDR 48, effective January 1, 1975; 4 SDR 60, effective March 26, 1978; 7 SDR 25, effective September 22, 1980; 13 SDR 129, 13 SDR 134, effective July 1, 1987; 19 SDR 154, effective April 11, 1993; 21 SDR 111, effective December 18, 1994; 22 SDR 165, effective June 2, 1996; 23 SDR 132, effective February 27, 1997; 36 SDR 27, effective August 23, 2009; 41 SDR 93, effective December 2, 2014.

General Authority: SDCL 32-25-7.

Law Implemented: SDCL 32-25-7.



Department of Transportation

Mitchell Office

P.O. Box 1206

Mitchell, South Dakota 57301

PHONE: 605/995-8129

FAX: 605/605-995-3185

DATE: July 18, 2017

TO: Christina Bennett
Operations Traffic Engineer

FROM: Scott Jansen
Mitchell Region Traffic Engineer

SUBJECT: Proposed Speed Limit Administrative Rule Change
State Trunk Highway 115 at Dell Rapids, South Dakota

Attached for the Transportation Commission's consideration is a speed limit administrative rule change on State Trunk Highway 115 through Dell Rapids, South Dakota.

EXISTING RULE:

70:01:02:01. Minnehaha County. The following are the maximum speeds on certain highways in Minnehaha County:

(10) State Trunk Highway 115 beginning 0.4 mile southeasterly of the intersection with Fourth Street in Dell Rapids, then northwesterly for 0.2 mile, 45 miles per hour; then northwesterly for 0.2 mile to Fourth Street, 30 miles per hour; then west for 0.2 mile, 30 miles per hour; then west for 0.45 mile, 45 miles per hour;

AMENDED RULE:

70:01:02:01. Minnehaha County. The following are the maximum speeds on certain highways in Minnehaha County:

(10) State Trunk Highway 115 beginning ~~0.4~~ 1.56 mile southeasterly of the intersection with Fourth Street in Dell Rapids, then northwesterly for ~~0.2~~ 1.08 mile, ~~45~~ 55 miles per hour; then northwesterly for ~~0.2~~ 0.48 mile to Fourth Street, ~~30~~ 35 miles per hour; then west for ~~0.2~~ 0.66 mile, ~~30~~ 35 miles per hour; then west for ~~0.45~~ 0.2 mile, ~~45~~ 50 miles per hour;

COST

The estimated cost to make the necessary signing changes, if this proposal is approved, is as follows:

Salvage Traffic Sign, 10 @ \$42.00 per sign = \$420.00

- This pays the Contractor to remove the existing signing

Flat Aluminum Sign Nonremovable Copy High Intensity, 35 Sq.Ft. @ \$9.71 per Sq.Ft. = \$339.85

- This pays for the new Speed Limit signs, measured per square foot of sign
- There are 7 new signs at 5.0 square feet per sign

Flat Aluminum Sign Nonremovable Copy Super/Very High Intensity,
9 Sq.Ft. @ \$11.81 per Sq.Ft. = \$106.29

- This pays for the new Reduced Speed Limit Ahead sign, measured per square foot of sign
- There is 1 new sign at 9.0 square feet per sign

2"x2" Perforated Tube Post, 81.55 Ft. @ \$12.60/Ft. = \$1,027.53

- This pays for all sign posts, hardware, and installation; measured per foot of post
- There are a total of 8 sign posts, with each sign having approximately 10 feet of post

TOTAL = \$1,893.67

Cost will be incurred with the reconstruction project. All costs were based on the contract unit bid prices and the plans estimate of quantities.

INFORMATION REGARDING PROPOSED SPEED LIMIT ADMINISTRATIVE RULE CHANGES

DATE: July 18, 2017

LOCATION:

Highway: State Highway 115

Town or City: Dell Rapids

County: Minnehaha

EFFECTS OF THE CHANGES:

Amend Existing Rule 70:01:02:01. (10)

PURPOSE OF THE CHANGES:

Adjust the administrative rule to reflect the change to the speed limits upon completion of the current construction project.

WHY THE CHANGES ARE RECOMMENDED:

The reconstruction and redesign of State Trunk Highway 115 required adjustment of the speed limits to accomplish the intended safety and function of the highway.

WHO INITIATED THE CHANGE:

The South Dakota Department of Transportation.

SPEED STUDY:

Several speed studies were conducted and used during project scoping to help determine redesign of the highway. The proposed speed limits are reflective of the studies conducted.

INVOLVEMENT WITH OTHER GOVERNING AGENCIES

The City of Dell Rapids agreed to the proposed speed limits during the scoping of the reconstruction project.

Existing Dell Rapids Speed Limit



Proposed Dell Rapids Speed Limit





Department of Transportation

Aberdeen Region Office

West Highway 12

PO Box 1767

Aberdeen, South Dakota 57402-1767 605/626-2244

FAX: 605/626-7875

TO: Christina Bennett
Operations Traffic Engineer

FROM: Corey Pinkley
Aberdeen Region Traffic Engineer

SUBJECT: Proposed Speed Limit Administrative Rule Change
US Highway 14 in Brookings

Attached for the Transportation Commission's consideration is a speed limit administrative rule change on US Highway 14 in Brookings, South Dakota.

EXISTING RULE:

70:01:02:06. Brookings County. The following are the maximum speeds on certain highways in Brookings County:

(4) U.S. Highway 14 beginning 0.21 mile west of Brookings County Road 9, then east and south for 1.41 miles, 55 miles per hour; then southeasterly for 0.25 mile, 40 miles per hour; then east for 1.68 miles, 30 miles per hour; then east for 0.98 mile, 35 miles per hour; then east for 0.36 mile, 45 miles per hour; then east for 0.16 mile, 55 miles per hour;

AMENDED RULE:

70:01:02:06. Brookings County. The following are the maximum speeds on certain highways in Brookings County:

(4) U.S. Highway 14 beginning 0.21 mile west of Brookings County Road 9, then east and south for 1.41 miles, 55 miles per hour; then southeasterly for 0.25 mile, 40 miles per hour; then east for 1.68 miles, 30 miles per hour; then east for ~~0.98 mile~~ 1.40 miles, 35 miles per hour; ~~then east for 0.36 mile, 45 miles per hour~~; then east for ~~0.16~~ 0.20 mile, ~~55~~ 50 miles per hour;

COST

Remove Traffic Sign, 5 @ \$11.50 per sign = \$57.50

- This pays the Contractor to remove the existing signing

Flat Aluminum Sign Nonremovable Copy High Intensity, 45 Sq.Ft. @ \$15.50 per Sq.Ft. = \$697.50

- This pays for the new Speed Limit signs, measured per square foot of sign
- There are 9 new signs at 5.0 square feet per sign

2"x2" Perforated Tube Post, 18.0 Ft. @ \$18.50/Ft. = \$333.00

- This pays for all sign posts, hardware, and installation; measured per foot of post
- There are a total of 2 sign posts that are 9 feet long each. 6 signs are being installed on luminaire poles, and one set of signs in the median is installed back-to-back on one post.

TOTAL = \$1,088.00

Cost will be incurred with the reconstruction project. All costs were based on the contract unit bid prices and the plans estimate of quantities.

INFORMATION REGARDING PROPOSED
SPEED LIMIT ADMINISTRATIVE RULE CHANGES

DATE: 07/19/2017

LOCATION:

Highway: US Highway 14

City: Brookings

County: Brookings County

EFFECTS OF THE CHANGES:

Amend Existing Rule 70:01:02:06 (4)

PURPOSE OF THE CHANGES:

The purpose of the change is to adjust the speed limits to due to changes in roadway geometrics from the reconstruction project.

WHY THE CHANGES ARE RECOMMENDED:

Construction is taking place in Brookings on US Highway 14 and the roadway geometrics are changing with the project. US Highway 14 (6th Street) in Brookings from just east of 22nd Ave. is currently a divided section with a depressed median and 10 Ft. outside shoulders, which then tapers back to a 2 lane road east of 32nd Ave. The new roadway through this same stretch will have curb and gutter on both sides with a raised center median. The existing roadway is what a typical rural section would look like and the new roadway has the geometrics of an urban highway. 35 mph is typical of an urban highway and would match the speed limit to the west to 22nd Ave. A transition speed of 50 mph would be posted between the 35 mph zone and the 65 mph speed limit to the east heading out of town.

Currently, just east of the northbound ramps on the interchange the speed limit changes to 45 mph and then to 55 mph just east of 34th Avenue. Due to roadway changes it is expected that the 85th percentile speed will decrease through this section east of the interchange.

WHO INITIATED THE CHANGE:

The SDDOT Aberdeen Region staff recommended the proposed changes. Lieutenant DeVaney of the SD Highway Patrol concurs with the proposed changes.

Existing

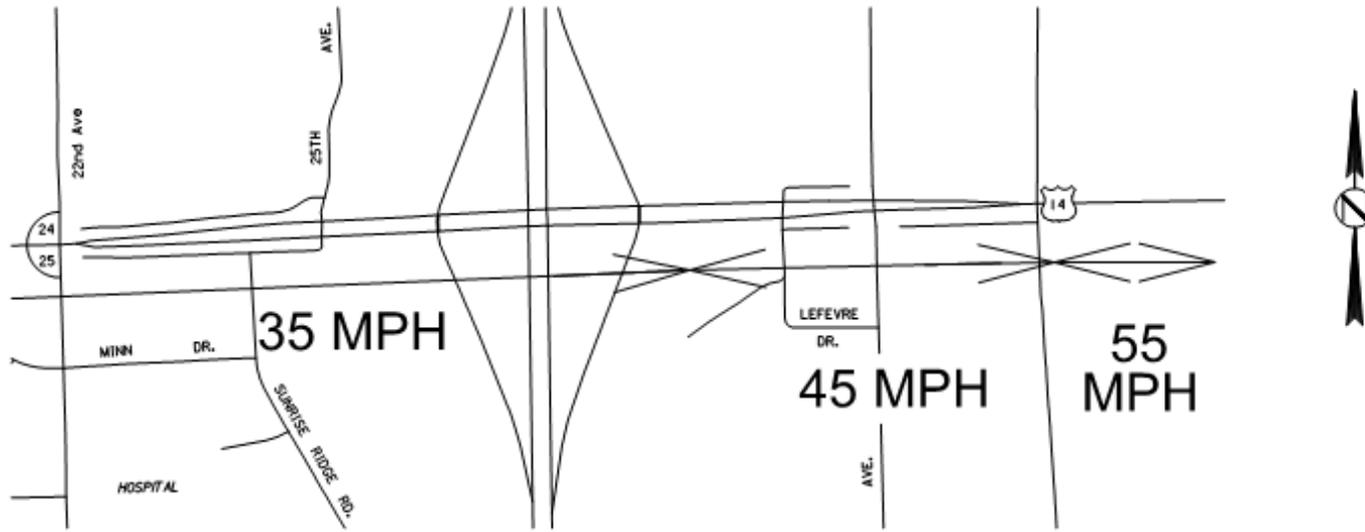

Brookings

Proposed

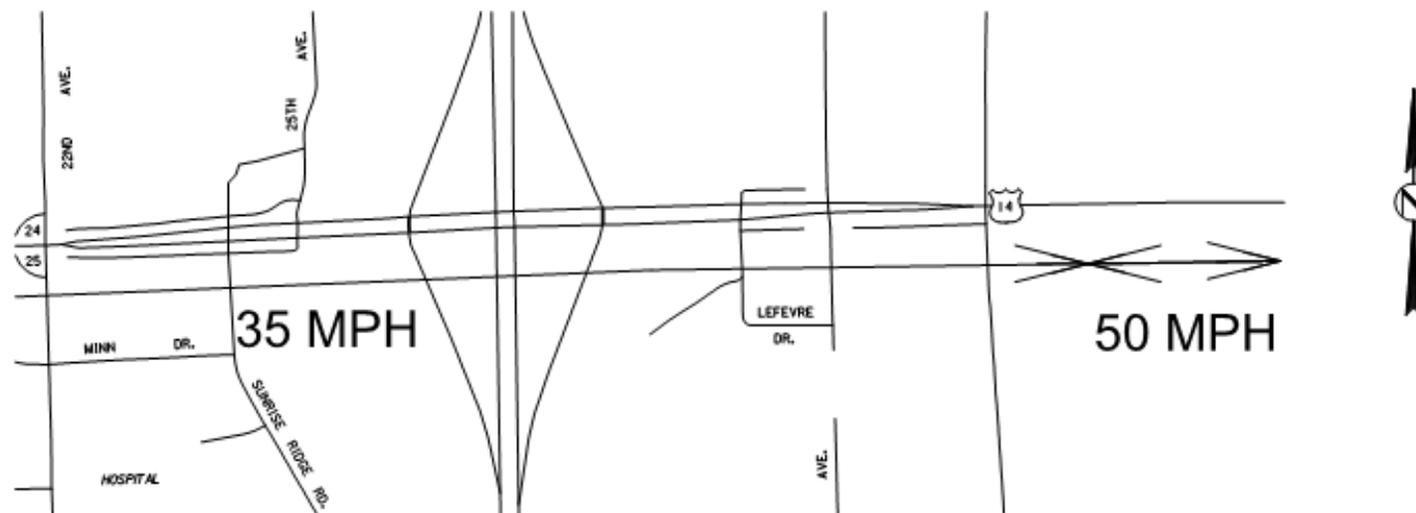

Brookings



Department of Transportation
Mitchell Region Office
1300 S Ohlman St
Mitchell, SD 57301
PHONE: 605-995-8129
FAX: 605-9958135

DATE: July 19, 2017

TO: Christina Bennett
Operations Traffic Engineer

FROM: Scott Jansen
Mitchell Region Traffic Engineer

SUBJECT: Proposed Speed Limit Administrative Rule Change
US Highway 18 over Interstate Highway 29 at Exit 62

Attached for the Transportation Commission's consideration is a speed limit administrative rule change on US Highway 18 over Interstate Highway 29 at Exit 62.

EXISTING RULE:

70:01:02:44. Lincoln County. The following are the maximum speeds on certain highways in Lincoln County:

(11) U.S. Highway 18 and the Lincoln County road over Interstate Highway 29 at Exit 62 beginning at a point 0.25 mile west of the centerline of Interstate Highway 29, then east 0.5 mile, 40 miles per hour;

AMENDED RULE:

70:01:02:44. Lincoln County. The following are the maximum speeds on certain highways in Lincoln County:

(11) U.S. Highway 18 ~~and the Lincoln County road~~ over Interstate Highway 29 at Exit 62 beginning at a point ~~0.25~~ 0.17 mile west of the centerline of Interstate Highway 29, then east ~~0.5~~ 0.53 mile, ~~40~~ 55 miles per hour;

COST

The estimated cost to make the necessary signing changes, if this proposal is approved, is as follows:

Salvage Traffic Sign, 6 @ \$31.50 per sign = \$189.00

- This pays the Contractor to remove the existing signing

Flat Aluminum Sign Nonremovable Copy High Intensity, 15 Sq.Ft. @ \$15.75 per Sq.Ft. = \$236.25

- This pays for the new Speed Limit signs, measured per square foot of sign
- There are 3 new signs at 5.0 square feet per sign

Flat Aluminum Sign Nonremovable Copy Super/Very High Intensity,
9 Sq.Ft. @ \$19.95 per Sq.Ft. = \$179.55

- This pays for the new Reduced Speed Limit Ahead sign, measured per square foot of sign
- There is 1 new sign at 9.0 square feet per sign

2"x2" Perforated Tube Post, 36.3 Ft. @ \$21.00/Ft. = \$762.30

- This pays for all sign posts, hardware, and installation; measured per foot of post
- There are a total of 4 sign posts, with each sign having approximately 9 feet of post

TOTAL = \$1,367.10

Cost will be incurred with the reconstruction project. All costs were based on the contract unit bid prices and the plans estimate of quantities.

INFORMATION REGARDING PROPOSED
SPEED LIMIT ADMINISTRATIVE RULE CHANGES

DATE: July 19, 2017

LOCATION:

I-29 Exit 62 US 18 Crossroad, Lincoln County

EFFECTS OF THE CHANGES:

Amend Existing Rule 70:01:02:44 (11)

PURPOSE OF THE CHANGES:

Adjust the administrative rule to reflect the change in speed limit as warranted with the reconstruction project.

WHY THE CHANGES ARE RECOMMENDED:

The reconstruction of the Interstate Highway 29 Interchange at Exit 62 allowed for adjustment of the speed limit to accomplish the intended safety and function of the highway. This is based on a speed study of US Highway 18 over Interstate Highway 29, in which the 85th percentile speeds justified a posted speed limit of 55 mph. This would continue the 55 mph speed zone posted on Lincoln County Road, which extends to the west of the Interchange.

WHO INITIATED THE CHANGE?

The Department of Transportation, in planning the Interchange reconstruction project.

SPEED STUDY:

Spot Speed Studies were conducted on the cross road near the centerline of Interstate Highway 29 for west bound and east bound traffic.

West Bound

Study Date: 07/13/2017

Time Period: 1:30 – 3:30pm

Average Speed: 47 mph

The 85th percentile speed: 53mph

Ten Mile Pace Speed: 44 to 54 mph

East Bound

Study Date: 07/13/2017

Time Period: 11:00 – 1:00pm

Average speed: 49 mph

The 85th percentile speed: 56 mph

Ten Mile Pace Speed: 45 to 55 mph

Based on the study, the existing 40 mph speed zone should be changed to a 55 mph speed zone.

INVOLVEMENT WITH OTHER GOVERNING AGENCIES

No other governing agencies are involved.

STATE OF SOUTH CAROLINA	PROJECT	SHEET	TOTAL SHEETS

Posting Date: 07/19/2017

I-29 EXIT 62 US 18 CROSSROAD

EXISTING

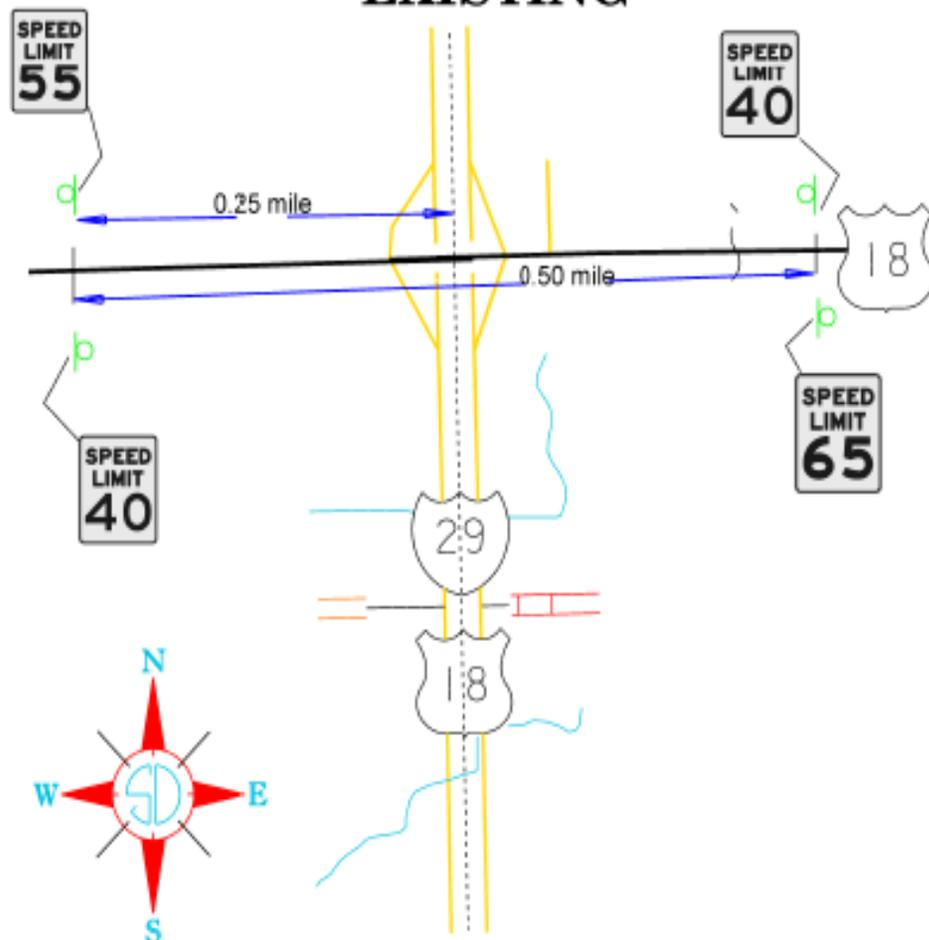

PROPOSED

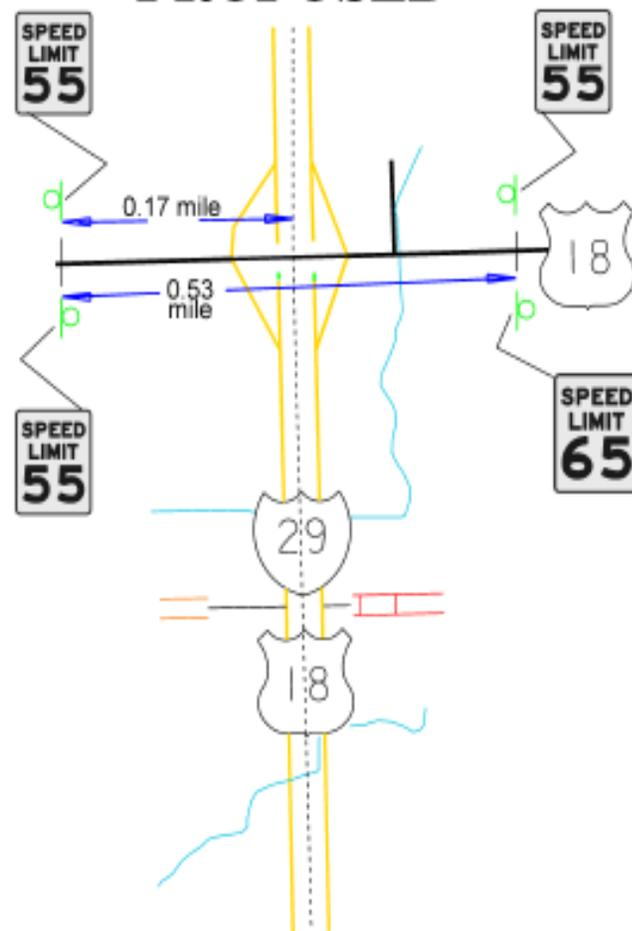

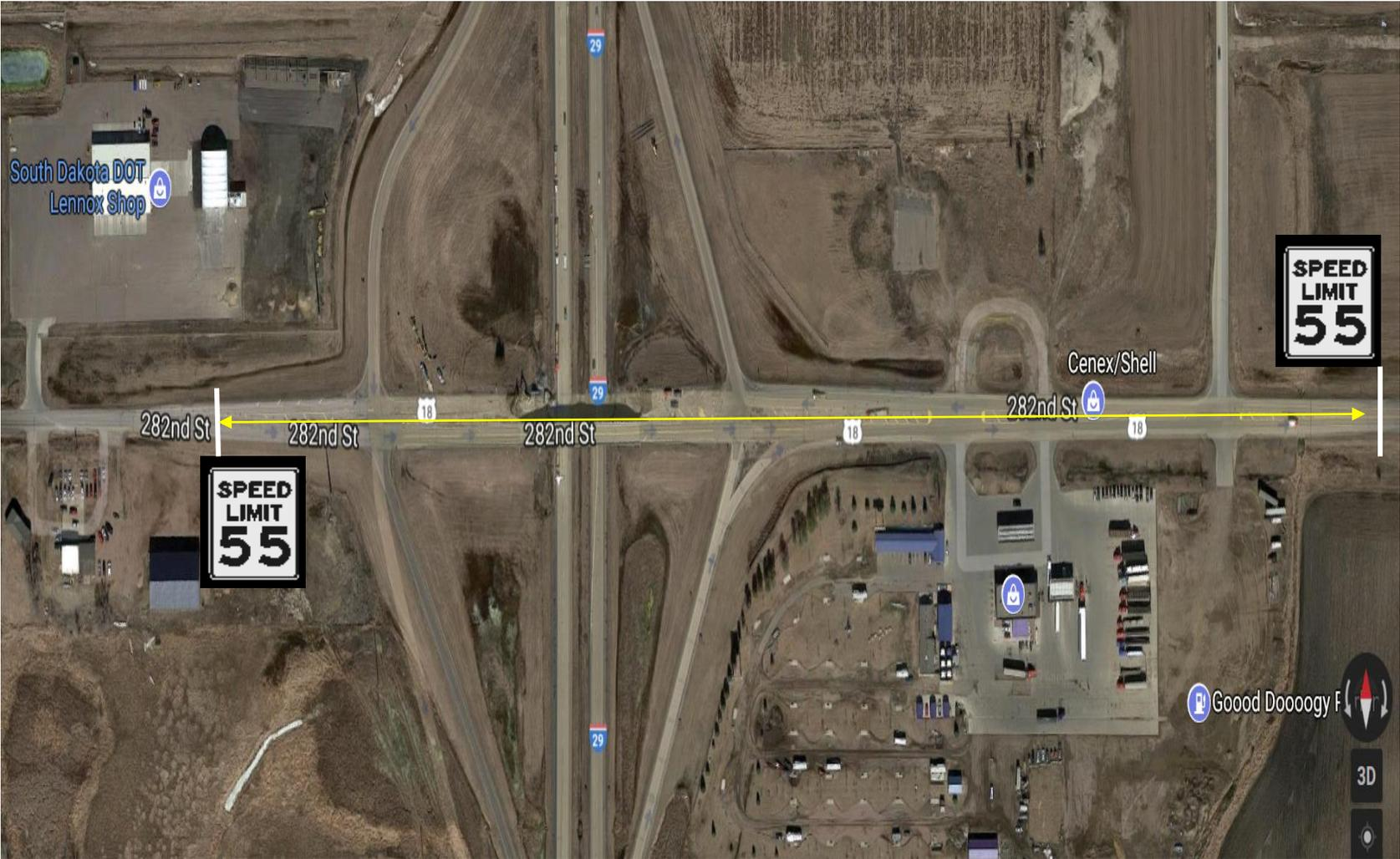



Department of Transportation

Pierre Region Office

104 S. Garfield

Pierre, South Dakota 57501-5405 605/773-3464

FAX: 605/773-6215

TO: Christina Bennett
Traffic Operations Engineer

FROM: Darren Griese
Pierre Region Traffic Engineer

SUBJECT: Proposed Speed Limit Administrative Rule Change
U.S. Hwy. 18 Todd County

DATE: July 19, 2017

Attached for the Transportation Commission's consideration is a speed limit administrative rule change on U.S. Hwy. 18 through Mission and east to the Antelope Community area in Todd County.

EXISTING RULE:

70:01:02:67 Todd County. The following are the maximum speeds on certain highways in Todd County:

(1) U.S. Highway 18 and U.S. Highway 83 beginning 2.1 miles west of the junction of U.S. Highway 18 and U.S. Highway 83 in Mission, then east for 1.1 miles, 45 miles per hour; then east for 1.4 miles, 30 miles per hour; then east for 1.1 miles, 45 miles per hour;

AMENDED RULE:

70:01:02:67 Todd County. The following are the maximum speeds on certain highways in Todd County:

(1) U.S. Highway 18 ~~and U.S. Highway 83~~ beginning 2.1 miles west of the junction of U.S. Highway 18 and U.S. Highway 83 in Mission, then east for 1.1 miles, 45 miles per hour; then east for ~~1.4~~ 1.0 mile to the junction of U.S. Highway 18 and U.S. Highway 83 in Mission, 30 miles per hour; then continuing east on U.S. Highway 18 for 0.98 mile, 30 miles per hour; then east for ~~1.1~~ 1.23 miles, 45 miles per hour;

COST

The estimated cost to make the necessary signing changes, if this proposal is approved, is as follows:

Relocate sign 6 @ \$75.00 per sign = \$ 450.00

TOTAL \$ 450.00

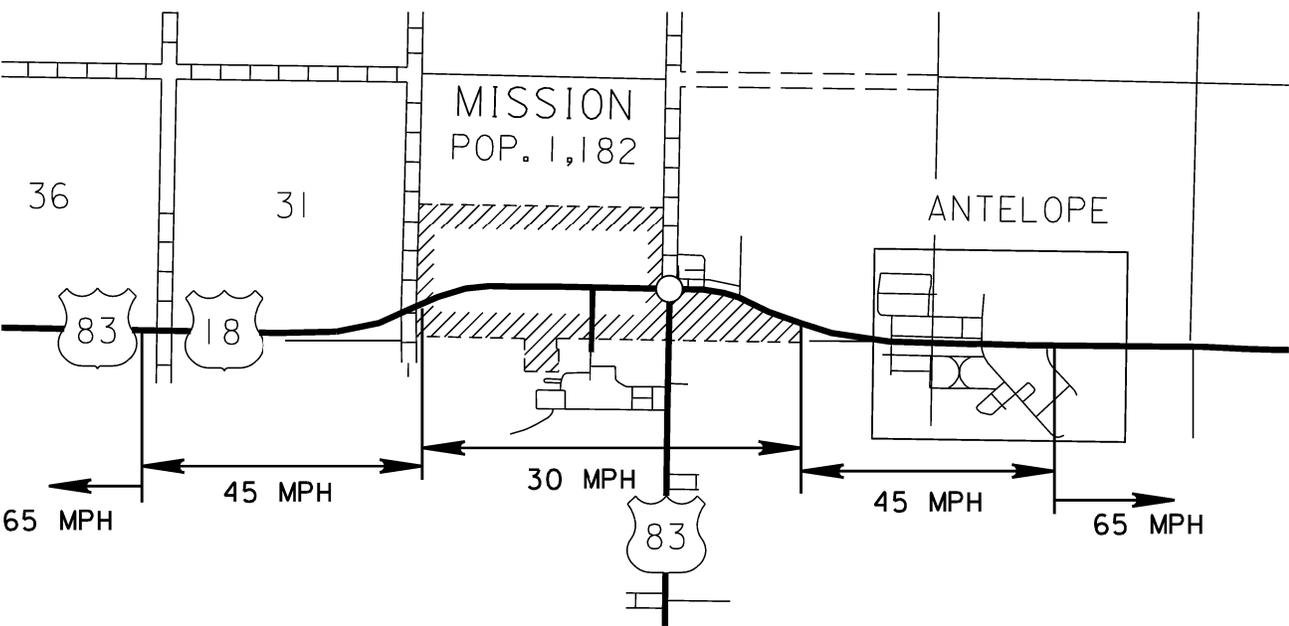

EXISTING

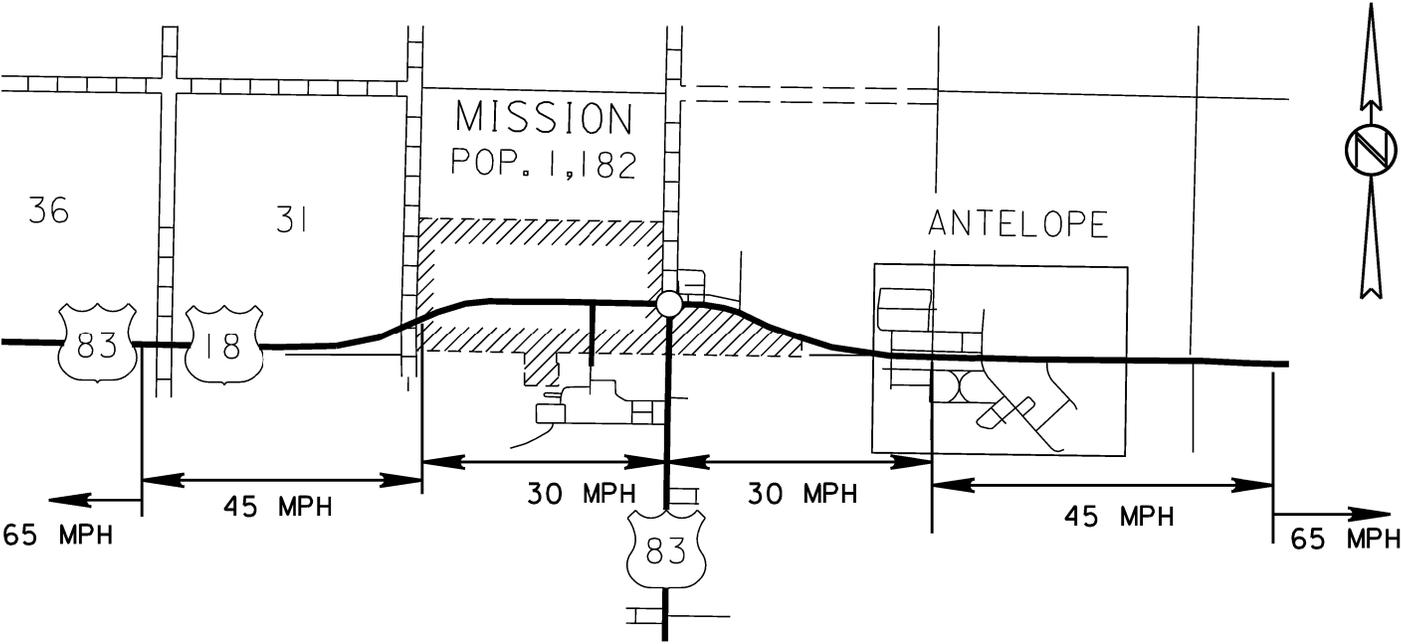

PROPOSED

INFORMATION REGARDING PROPOSED
SPEED ZONE RULE

DATE: July 19, 2017

LOCATION:

Highway: U.S. 18 & U.S. 83

Town or City: Mission

County: Todd

EFFECT OF THE CHANGE:

Amend existing rule 70:01:02:67 (1)

PURPOSE OF THE CHANGE:

The purpose of this proposed amended rule is to create a slower speed limit through the town of Mission, along the segment of U.S. Highway 18 that is being widened to three lanes. This will cause traffic to be closer to the pedestrian path. The change will also extend the 45 mph speed zone past the Antelope community on the east side of town.

WHY IS CHANGE RECOMMENDED:

To safely accommodate traffic and pedestrians along the new three lane section of U.S. Highway 18. This change is to slow traffic which will be closer to the pedestrian path and extend a speed zone heading out of town past the Antelope community.

WHO INITIATED CHANGE:

This change is requested by the South Dakota Department of Transportation Winner Area Office and the Rosebud Sioux Tribe Map 21 Program.

Captain Jason Ketterling, South Dakota Highway Patrol, is in support of the proposed speed rule.

Interim Rules Review Committee Recommended Rules Presentation Format

When you submit the final draft to the Legislative Research Council (LRC) and the Rules Review Committee, please answer these questions to show that the SDCL § 1-26 rule-making process is complete. Use this format to organize your presentation to the Committee.

- Approval to proceed? Yes No Date July 25, 2017
- The date of your public hearing. Date August 24, 2017
- The date you submitted the proposed rules and the supporting documents to LRC and the Bureau of Finance and Management: Date July 31, 2017 (Note - This must be completed at least 20 days before your public hearing.)
 - any publication incorporated by reference;
 - the fiscal note;
 - the impact statement on small business; and
 - the notice of hearing.
- The date and the name of the newspapers where you published the notice of the public hearing.
 - Date August 3, 2017 Newspaper Sioux Falls Argus Leader
 - Date August 2, 2017 Newspaper Brookings Register
 - Date August 2, 2017 Newspaper Winner Advocate
 - Date August 2, 2017 Newspaper Todd County Tribune
- Summarize how and when interested persons, if any, were contacted and how many were contacted.
The hearing notice and draft rules were mailed to fourteen individuals and entities who have requested notification of rulemaking by the Transportation Commission. In addition, the hearing notice and draft rules were sent by electronic mail to a member of the press who has requested electronic notification of rulemaking by the commission. The hearing notice and draft rules were also mailed to the sheriffs of Minnehaha, Brookings, Lincoln, and Todd Counties. The mayors and finance officers of the cities of Mission, Brookings, and Dell Rapids were also provided with a copy of the hearing notice and draft rules by mail. All of these mailings were done on July 31, 2017.
- Provide the page numbers in the minutes where it mentions how the agency considered amendments, data, opinions, or arguments regarding the proposed rules, along with any changes and final action. _____
- If the rules are implementing a bill from last session, identify the bill number. N/A
- The date you submitted the final rules and supporting documents to the LRC and the Rules Review Committee: Date _____ (Note - This must be received no later than 5 days before the Rules Review Committee meeting.)
 - the "Approval of Rules" - Form 11 (LRC only);
 - the style and form copy (LRC only);
 - the "Affidavit" of mailing - Form 12 (LRC only);

- the final copy of the rules (Both);
- the minutes of the hearing (Both);
- the record of written comments (Both);
- the impact statement on small business – Form 14 (Committee only);
- the fiscal note – Form 5 (Committee only);
- the budgetary information required to increase a fee (Committee only); and
- the rules process outline (Both).